

MODEL 7771 STANDARD RIGID COUPLING - T&G Design -

The Model 7771 Standard Rigid Coupling is the ideal choice for risers, mechanical rooms or other applications where rigidity is required. The tongue and groove design and mechanisms provide a rigid connection reducing and or eliminating flexural and torsional loads. The Model 7771 coupling sizes 1½" - 12" (40 mm – 300 mm) are comprised of two identical housing segments, sizes 14" - 18" (350 mm – 400 mm) are comprised of three identical segments and sizes 20" - 24" (500 mm – 600 mm) are comprised of four identical segments. All include an EPDM rubber gasket and plated track bolts and nuts. Housing segments are supplied with our standard painted finishes, i.e. orange or RAL3000 red. Optional finishes such as hot dipped zinc galvanized and custom epoxy coatings are available.

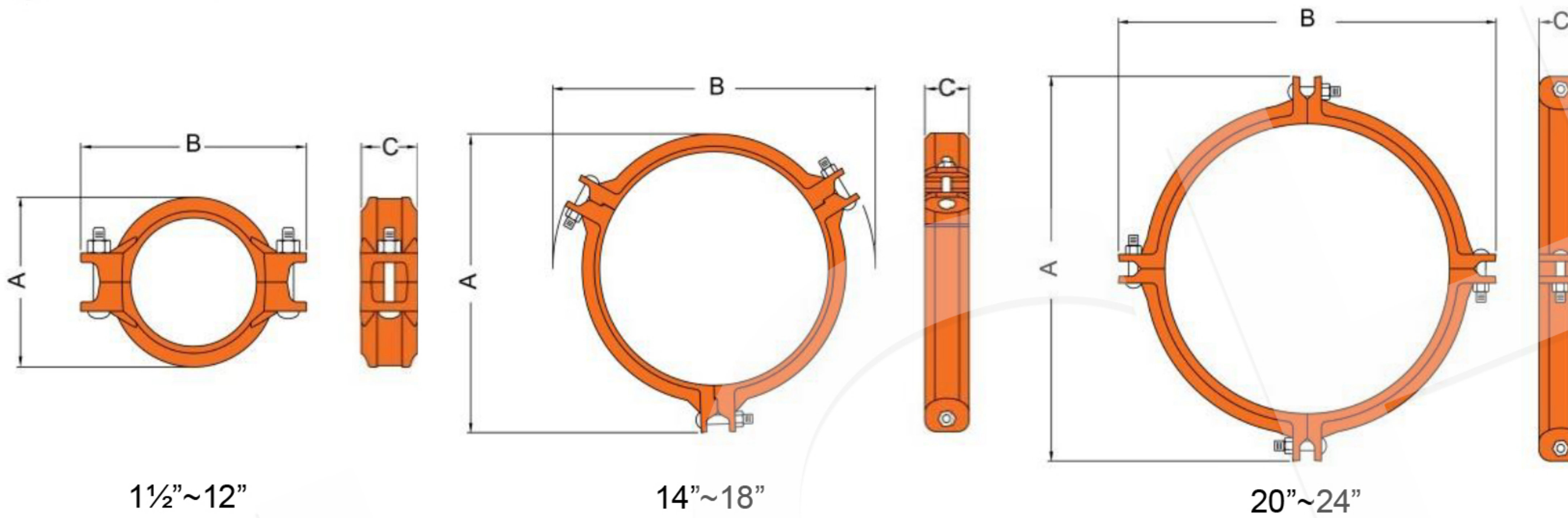

7771 couplings should always be installed so that the coupling bolt pads make metal to metal contact.



**10
YEAR
LIMITED
WARRANTY**

Full warranty terms can be found on www.shurjoint.com

Model 7771 Standard Rigid Coupling

Nominal Size	Pipe O.D.	Max. Working Pressure (CWP)*	Max. End Load (CWP)	Axial Displacement †	Dimensions			Bolt		Weight
					A	B	C	No.	Size	
in mm	in mm	PSI Bar	Lbs kN	in mm	in mm	in mm	in mm	No.	in mm	Lbs Kgs
1½ 40	1.900 48.3	500 35	1410 6.23	0~0.06 0~1.6	2.91 74	4.41 112	1.81 46	2	¾ x 2½ M10 x 55	1.5 0.7
2 50	2.375 60.3	500 35	2210 9.70	0~0.06 0~1.6	3.34 85	4.96 126	1.81 46	2	¾ x 2½ M10 x 55	1.9 0.9
2½ 65	2.875 73.0	500 35	3240 14.22	0~0.06 0~1.6	3.89 99	5.59 142	1.81 46	2	¾ x 2½ M10 x 55	2.6 1.2
76.1 mm	3.000 76.1	500 35	3530 15.46	0~0.06 0~1.6	4.00 102	5.90 150	1.81 46	2	¾ x 2½ M10 x 55	2.6 1.2
3 80	3.500 88.9	500 35	4800 21.09	0~0.06 0~1.6	4.52 115	6.50 165	1.81 46	2	½ x 3 M12 x 75	3.3 1.5
108.0 mm	4.250 108.0	500 35	7090 31.13	0~0.16 0~4.1	5.54 141	7.59 193	2.00 51	2	½ x 3 M12 x 75	4.8 2.2
4 100	4.500 114.3	500 35	7940 34.87	0~0.16 0~4.1	5.82 148	7.79 198	2.00 51	2	½ x 3 M12 x 75	4.8 2.2
133.0 mm	5.250 133.0	450 31	9730 43.05	0~0.16 0~4.1	6.61 168	9.72 247	2.00 51	2	⅝ x 3½ M16 x 90	6.0 2.7
139.7 mm	5.500 139.7	450 31	10680 47.49	0~0.16 0~4.1	6.8 173	9.45 240	2.00 51	2	⅝ x 3½ M16 x 90	6.4 2.9
5 125	5.563 141.3	450 31	10930 48.59	0~0.16 0~4.1	6.88 175	9.84 250	2.00 51	2	⅝ x 3½ M16 x 90	6.4 2.9

Model 7771 Standard Rigid Coupling

Nominal Size	Pipe O.D.	Max. Working Pressure (CWP)*	Max. End Load (CWP)	Axial Displacement †	Dimensions			No.	Bolt	
					A	B	C		Size	Weight
in mm	in mm	PSI Bar	Lbs kN	in mm	in mm	in mm	in mm	in mm	Lbs Kgs	
165.1 mm	6.500 165.1	450 31	14920 66.33	0~0.16 0~4.1	7.87 200	11.02 280	2.09 53	2	5/8 x 3 1/2 M16 x 90	7.7 3.5
6 150	6.625 168.3	450 31	15500 68.93	0~0.16 0~4.1	8.07 205	11.18 284	2.09 53	2	5/8 x 3 1/2 M16 x 90	8.1 3.7
8 200	8.625 219.1	300 20	17510 75.37	0~0.16 0~4.1	10.27 261	13.58 345	2.48 63	2	5/8 x 5 5/16 M16 x 135	14.6 6.6
10 250	10.750 273.0	300 20	27210 117.01	0~0.16 0~4.1	12.44 316	15.51 394	2.50 64	2	3/4 x 4 3/4 M20 x 120	18.6 8.4
12 300	12.750 323.9	300 20	38280 164.71	0~0.16 0~4.1	14.17 360	18.00 457	2.50 64	2	7/8 x 6 1/2 ---	24.5 11.1
200 JIS	8.516 216.3	300 20	17070 73.45	0~0.16 0~4.1	10.00 254	13.58 345	2.48 63	2	5/8 x 5 5/16 M16 x 135	15.2 6.9
250 JIS	10.528 267.4	300 20	26100 112.26	0~0.16 0~4.1	12.20 310	15.20 386	2.50 64	2	3/4 x 4 3/4 M20 x 120	19.3 8.7
300 JIS	12.539 318.5	300 20	37020 159.26	0~0.16 0~4.1	13.94 354	17.48 444	2.50 64	2	7/8 x 6 1/2 ---	26.0 11.2
14 350	14.000 355.6	300 20	46150 198.53	0~0.13 0~3.2	16.25 413	20.28 515	2.95 75	2	7/8 x 4 ---	31.9 14.5
16 400	16.000 406.4	300 20	60280 259.30	0~0.13 0~3.2	18.11 460	22.17 563	2.95 75	3	7/8 x 4 ---	35.2 16.0
18 450	18.000 457.2	300 20	76300 328.18	0~0.13 0~3.2	20.51 521	24.21 615	3.11 79	3	7/8 x 4 ---	37.4 17.0
20 500	20.000 508.0	300 20	94200 405.16	0~0.13 0~3.2	22.87 581	26.26 667	3.11 79	4	1 x 3 1/2 ---	52.8 24.0
22 550	22.000 558.8	250 17	94980 416.71	0~0.13 0~3.2	24.49 622	28.35 720	3.11 79	4	1 x 3 1/2 ---	58.3 26.5
24 600	24.000 609.6	250 17	113040 495.92	0~0.13 0~3.2	27.12 689	30.24 768	3.11 79	4	1 x 3 1/2 ---	62.6 28.4

* Working Pressure is based on roll grooved standard wall carbon steel pipe.

† Allowable Axial Displacement and Angular Movement (deflection) figures are for roll grooved standard steel pipe. Values for cut grooved pipe will be double that of roll grooved. These values are maximums; for design and installation purposes these figures should be reduced by: 50% for 3/4" – 3 1/2"; 25% for 4" and larger to compensate for jobsite conditions.

steam services unless valves or components are accessible for frequent replacement.

MATERIAL SPECIFICATIONS

• Housing:

Ductile Iron to ASTM A536, Gr. 65-45-12 and or to ASTM A395, Gr. 65-45-15, min. tensile strength 65,000 psi (448 MPa).

• Surface Finish:

Standard painted finishes in orange or RAL3000 red.

- Hot dip zincgalvanized (Option).
- Epoxy Coatings in RAL3000 red or other colors (Option).

For additional details contact **Shurjoint**.

• Rubber Gasket:

Grade E-pw EPDM (Color code: Double Green stripe) approved under NSF/ANSI 61 and NSF/ANSI 372 for potable water service to +180°F (+82°C). Also good for services for water with acid, water with chlorine or chloramines, deionized water, seawater and waste water, dilute acids, oil-free air and many chemicals.

Not recommended for petroleum oils, minerals oils, solvents and aromatic hydrocarbons.

Maximum Temperature Range: -30°F (-34°C) to +230°F (+110°C)*.

*EPDM seat for water services are not recommended for

- (Option) **Grade "E" EPDM** (Color code: Green stripe) Good for cold & hot water up to +230°F (+110°C). Also good for services for water with acid, water with chlorine, deionized water, seawater and waste water, dilute acids, oil-free air and many chemicals. **Not recommended for petroleum oils, minerals oils, solvents and aromatic hydrocarbons.**

Maximum Temperature Range: -30°F (-34°C) to +230°F (+110°C)*.

*EPDM seat for water services are not recommended for steam services unless valves or components are accessible for frequent replacement.

- (Option) **Grade “T” Nitrile** (Colorcode: Orange stripe) Recommended for petroleum products, air with oil vapors, vegetable and mineral oils within the specified temperature range. Also good for water services under +150°F (+66°C).
Temperature range: -20°F to +180°F (-29°C to +82°C). **Do not use for HOT WATER above +150°F (+66°C) or HOT DRY AIR above +140°F (+60°C)**
- Other options: Grade “O” -Fluoroelastomer.
Grade “L” -Silicone.

For additional details contact **Shurjoint**.

• **Bolts & Nuts:**

Heat treated carbon manganese steel track bolts to ASTM A449-83a (or A183 Gr. 2), minimum tensile strength 110,000 psi (758 MPa), Zinc electroplated, with heavy-duty hexagonal nuts to ASTM A563 Type 304 or 316 track bolts with heavy duty nuts (Option).

Performance Data

The following tables show the maximum working pressures (CWP) of **Shurjoint** Model 7771 Standard Rigid Coupling used on both carbon steel and stainless steel pipes. **Shurjoint** ductile iron couplings can be used in conjunction with stainless steel pipe in non-corrosive environment as the flow media does not come in direct contact with the coupling housings but rather only the gasket.

Unit: psi / Bar

Unit: psi / Bar

Model 7771 on Carbon Steel Pipe					
Nom. Size	Cut-Grooved		Roll-Grooved		
	XS	STD	STD	Sch. 10	Sch. 7
in / mm					
1½ 40	750 52	750 52	750 52	600 42	400 28
2 50	750 52	750 52	750 52	600 42	400 28
2½ 65	750 52	750 52	750 52	600 42	400 28
3 80	750 52	750 52	750 52	600 42	400 28
4 100	750 52	750 52	750 52	600 42	400 28
5 125	750 52	750 52	750 52	500 35	350 24
6 150	700 48	700 48	700 48	400 28	300 20
8 200	600 42	600 42	600 42	350 24	250 17
10 250	500 35	500 35	500 35	300 20	200 14
12 300	400 28	400 28	400 28	250 17	150 10

Model 7771 on Stainless Steel Pipe					
Nom. Size	Cut-Grooved		Roll-Grooved		
	Sch. 80S	Sch. 40S	Sch. 40S	Sch. 10S	Sch. 5S
in / mm					
1½ 40	750 52	750 52	700 48	500 35	300 20
2 50	750 52	750 52	700 48	500 35	300 20
2½ 65	750 52	750 52	700 48	500 35	300 20
3 80	750 52	750 52	700 48	500 35	300 20
4 100	750 52	750 52	700 48	400 28	250 17
5 125	750 52	750 52	600 42	300 20	NR
6 150	700 48	700 48	500 35	200 14	NR
8 200	600 42	600 42	400 28	150 10	NR
10 250	500 35	500 35	300 20	100 7	NR
12 300	400 28	400 28	250 17	100 7	NR

General Notes:

- **Maximum Working Pressure (CWP)** listed is the maximum cold water pressure for general piping services tested to ASTM F1476 and or AWWA C606 methods. Figures listed are based on roll- or cut-grooved standard wall carbon steel pipe. For other pipe schedules or pipe materials, contact **Shurjoint** for additional information.
- **Max. End Load** is calculated based on the maximum working pressure (CWP).
- **Listed and or Approved Pressures** are pressure ratings for fire protection systems, tested and approved by various approval bodies. Please always refer to the latest approval data posted on the **Shurjoint** website.
- **Field Joint Test:** For one time only the system may be tested hydrostatically at 1½ times the maximum working pressure listed (AWWA C606 5.2.3).
- **Warning:** Piping systems must always be depressurized and drained before attempting disassembly and or removal of any components.
- **The 10 Year Limited Warranty** applies to manufacturing defects only and does not cover severe service/temperature applications or wear parts.
- **Shurjoint** reserves the right to change specifications, designs and or standard without notice and without incurring any obligations.